

LD170 with new E1 LED Light Engine

High Power LED Interior/Exterior Wall Light



Data sheet - Page 1



Design: Maurice Brill Lighting Design
Project: 20 Fenchurch Street, Sky Garden - Product: Custom LD170

The new LD170 features an all new E1 LED engine and a newly revised optic. This recessed wall light features an oval beam optic and angled kick lens, which focuses the light down on to the lit surface. The result is glare-free, broad and even illumination to steps and pathways. A very tough, high quality fitting, suitable for a wide range of applications.

Key Features

- New E1 engine, featuring the CREE XHP35 LED with 2-step binning
- New optional 2nd channel LEDs for secondary lighting applications
- Integral glare baffle which minimises the light above the horizontal
- Single optic produces a very consistent beam with no multiple shadows
- 20° angled kick lens focuses the light down on to the lit surface
- LED and lens recessed in a matt black anodised body for reduced glare
- No visible fixings
- Range of bezel finish options
- Built-in reverse polarity protection
- Available with Switch, 0-10V, DMX, Dali or Mains dimmable drivers

**Specification**

Applications



LED type	1 x E1 LED Engine with 2-step binning (LED data below)			
Colour temperature	2700K** / 3000K / 4000K		5000K	
Current	350mA	500mA	350mA	500mA
LED power (Max)	5W (4.4W)*	7W (6.3W)*	5W (4.4W)*	7W (6.4W)*
CRI (Min)	85	85	80	80
Forward voltage (V) ₁₀₀	14V	14V	14V	14V
Delivered lumens (L ₁₀₀)	182	210	195	225
LED lifetime (to 70% lumen maintenance)	50,000hrs at a max ambient temperature of 45°C (if higher ambient then run at 350mA up to 55°C)			
Glass	6mm thick low iron glass			
Materials	Black anodised aluminium body, Machine finish 316 stainless steel bezel (other options available) Sleeve - Black Acetal			
Wiring	Comes pre-wired with 250mm lead. Single colour equipped with 2 core cable & 2 Channel with 4 core cable. Can be specified with up to 10m at extra cost.			
IP rating	IP67			

*indicates the nominal power for the LED run at that particular current and includes losses associated with using an 85% efficient driver

**2700K lumen output is 8% lower than the 3000K figure listed

LD170 with new E1 LED Light Engine

High Power LED Interior/Exterior Wall Light



Data sheet - Page 2

Fixing and Dimensions

The fitting is supplied as standard with a fixing sleeve; this is bonded into the mounting surface first. It is secured into the sleeve by 2 O-rings on the body. When pushed into the sleeve it creates a watertight seal.

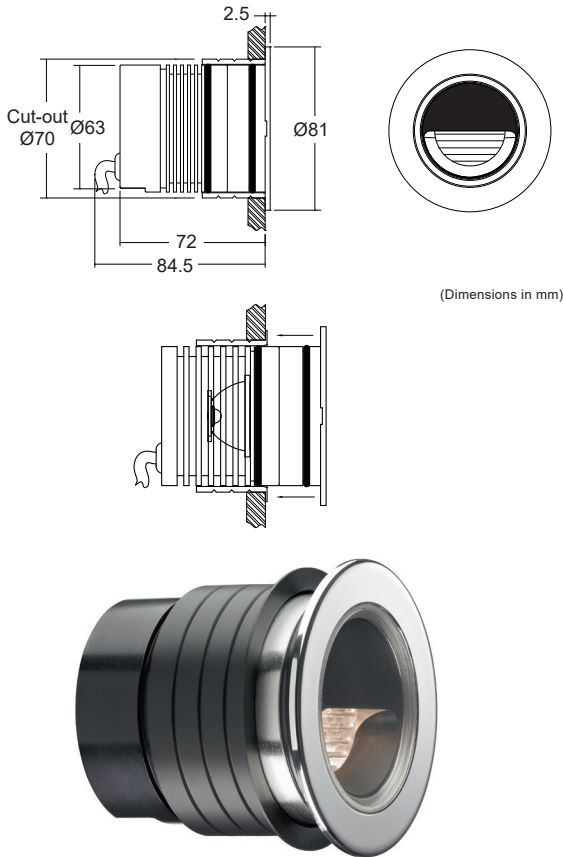

LED Options and Technology

New LED Options

LD170 is now available with a choice of light engines which feature a new all copper board for increased thermal transfer. The new E1 light engine for white light applications uses the new Cree XHP35 LED and features on board polarity protection. This engine is also available with two extra LEDs on a second channel, for night lighting and marine navigation applications.

	E1 Light Engine (White light applications)	E1 Light Engine with 2nd channel
LED Board		
LED type	Cree XHP35	Cree XHP35 + XQE's
Key features	<ul style="list-style-type: none"> - Available in 2700K, 3000K, 4000K and 5000K - Very small chip size - Tighter narrow beam - Wider range of beam angles - 2 step binning - Brighter more efficient LED - On board polarity protection - All copper LED board for increased thermal transfer 	<ul style="list-style-type: none"> - Main white LED with optional 2nd channel for night lighting or marine navigation applications - 2nd channel comprises of 2 XQE LEDs mounted next to the XHP35 - Beam shape from the XQE's is different from the main LED as they are not centralised within the optic - Mixing is not recommended - 2 driver circuits required - All copper LED board
Cables		

Industry Leading LED Thermal Management

High quality, embedded copper PCB, with direct contact cooling for the LEDs providing industry leading thermal management of the LED. Guaranteeing long life and minimal colour shift.



LD170 with new E1 LED Light Engine

High Power LED Interior/Exterior Wall Light

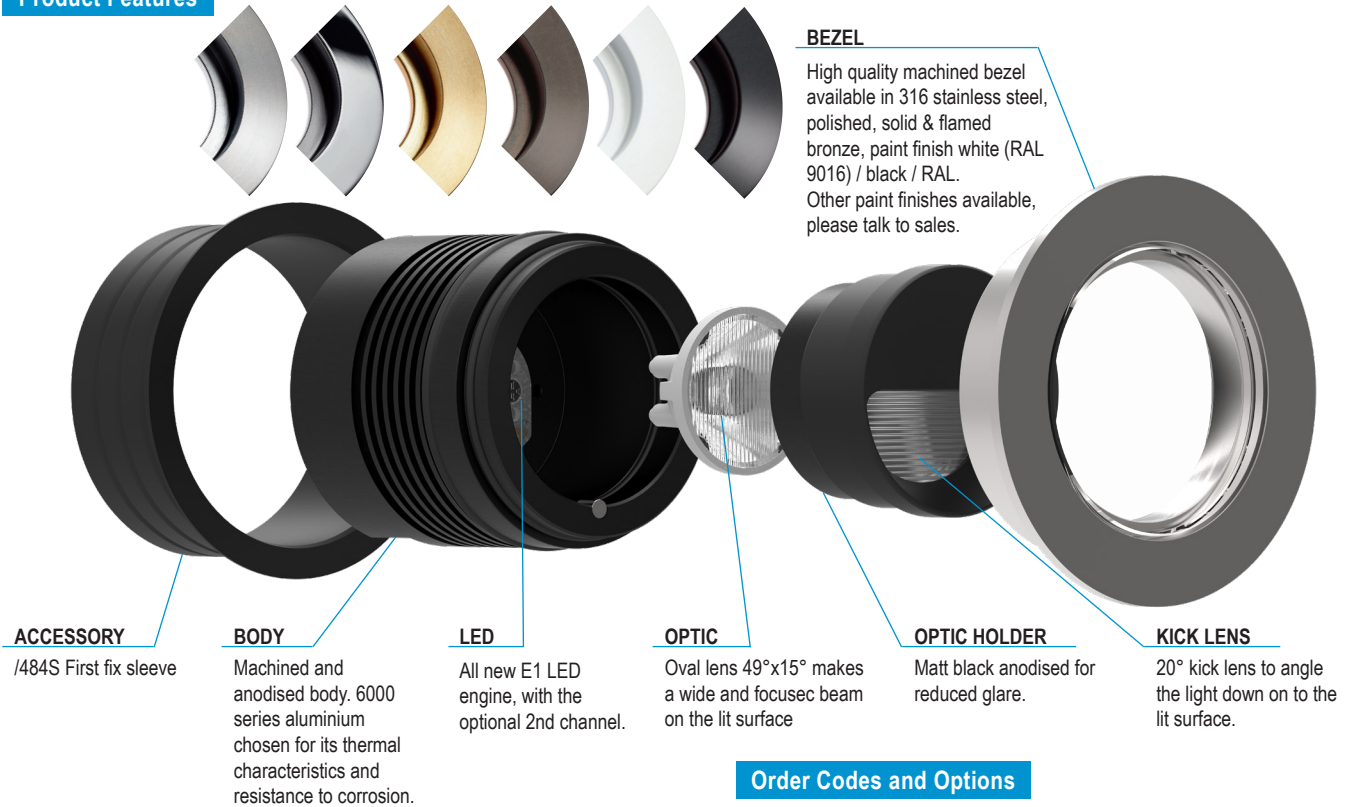

Data sheet - Page 3

Product Features**ACCESSORY**

/484S First fix sleeve

BODY

Machined and anodised body. 6000 series aluminium chosen for its thermal characteristics and resistance to corrosion.

LED

All new E1 LED engine, with the optional 2nd channel.

OPTIC

Oval lens 49°x15° makes a wide and focusec beam on the lit surface

OPTIC HOLDER

Matt black anodised for reduced glare.

KICK LENS

20° kick lens to angle the light down on to the lit surface.

BEZEL

High quality machined bezel available in 316 stainless steel, polished, solid & flamed bronze, paint finish white (RAL 9016) / black / RAL. Other paint finishes available, please talk to sales.

Order Codes and Options

Product code	LED colour	Finish
LD170-E1 - 350 - 500	<input type="text"/>	<input type="text"/>
Example: LD170-E1-500 / LW30 / Stainless Steel		

Product codes with output options

5W LED at 350mA	LD170-E1-350
7W LED at 500mA	LD170-E1-500

LED colour options

LED colour options	Suffix
Extra Warm White (2700K)	/LW27
Warm White (3000K)	/LW30
White (4000K) - on request	/LW40
Cool White (5000K)	/LW50
With 2nd channel (red for navigation or amber night lighting) LD170-E1-2CH	/LW**+L*

For other single colour options, please discuss with sales team

Bezel finish options

Stainless steel 316
 Polished and passivated stainless steel (for marine environments)
 Flamed solid bronze (antique finish)
 Paint finish black / white (RAL 9016) / antique bronze / satin antique brass / satin brass / RAL finish

Fixing accessories

Comes standard with /484S first fix sleeve

Use with 350mA & 500mA constant current LED drivers

We have a wide range of dimmable LED drivers, 0-10V, DMX, DALI and Mains dimmable. Please see the downloads section on our website:
 To run 1-4 LD170-E1-350 in series use a TXDEL350D (0-10V dimmable)
 To run 1-4 LD170-E1-500 in series use a TXDEL500D (0-10V dimmable)